

Assessing Wind Energy Potential in Markazi Province, Iran: A Data-Driven Approach with AI Algorithms

Amir Hossein Karamali, Abolghasem Daeichian, Saber Rezaei, Ali Reihanian

Highlights

- ❖ Suggesting suitable locations for wind power plants in Markazi Province by analyzing real wind speed data
- ❖ Analyzing wind patterns using a combination of statistical approaches and artificial intelligence techniques
- ❖ Conducting statistical analysis using the Weibull distribution and wind rose diagrams
- ❖ Employing Long Short-Term Memory network to predict wind speeds and temporal trends.

Graphical Abstract



Use your device to scan
and read the article
online



Citation

A. H. Karamali, A. Daeichian, S. Rezaei, and A. Reihanian, "Assessing Wind Energy Potential in Markazi Province, Iran: A Data-Driven Approach with AI Algorithms," *Journal of Green Energy Research and Innovation*, vol. 2, no. 2, pp. 26-35, 2025.



<https://doi.org/10.61186/jgeri.2.2.26>

© Author





Online ISSN: 3041-9018

Journal of Green Energy Research and Innovation

Journal Homepage: www.jgeri.araku.ac.ir

Assessing Wind Energy Potential in Markazi Province, Iran: A Data-Driven Approach with AI Algorithms

Amir Hossein Karamali ¹, Abolghasem Daeichian ^{2,3}, Saber Rezaei ¹, Ali Reihanian ^{3,4,*}

¹ Department of Electrical Engineering, Iran University of Science and Technology, Tehran, Iran.

² Department of Electrical Engineering, Faculty of Engineering, Arak University, Arak, 38156-8-8349, Iran.

³ Research Institute of Artificial Intelligence, Arak University, Arak, 38156-8-8349, Iran.

⁴ Department of Computer Engineering, Faculty of Engineering, Arak University, Arak, 38156-8-8349, Iran.

ARTICLE INFO

Keywords:

Wind Energy Potential,
Wind rose,
Weibull Function,
Long Short-Term Memory,
Renewable energy.

Article History:

Received: 12 December 2024;
Revised: 06 January 2025;
Accepted: 18 January 2025.

Article type:

Research Article

* Corresponding author

E-mail address

a-reihanian@araku.ac.ir (A. Reihanian)

ABSTRACT

This paper investigates the wind energy potential in Markazi Province, Iran, focusing on three cities: Tafresh, Khomein, and Saveh. The primary objective of this study is to provide a comprehensive analysis of wind patterns using a combination of statistical approaches and artificial intelligence techniques. Wind data was collected from advanced meteorological stations in these cities over two years (2018–2020), including detailed measurements of wind speed and direction at 10-minute intervals. This high-resolution dataset facilitated an in-depth examination of wind behavior and its suitability for energy production. Statistical analysis was conducted using the Weibull distribution and wind rose diagrams, which provided insights into the wind characteristics and their spatial variations. Additionally, Long Short-Term Memory (LSTM) networks were employed to predict wind speeds and temporal trends. These models effectively captured the complex relationships within the wind data and produced highly accurate forecasts. The comparison of actual and predicted wind rose diagrams demonstrated a strong alignment, validating the reliability of the LSTM-based predictions in reflecting real-world wind patterns. The results of this study demonstrate that combining traditional statistical methods with modern machine learning techniques provides a robust framework for analyzing wind energy potential. By leveraging these tools, the study offers valuable insights for sustainable energy planning and supports informed decision-making for renewable energy investments in Markazi Province.

1. Introduction

The study of wind speed patterns and the assessment of wind energy potential are critical in renewable energy planning [1]. Numerous studies have employed various techniques to analyze wind characteristics and evaluate wind energy potential across diverse regions. For example, the variability of wind speeds and power potential has been frequently examined using the Weibull distribution [2]. However, while the Weibull distribution remains a popular tool for modeling wind speed, its limitations in capturing multimodal and highly variable wind speed distributions are often overlooked.

In [3], the performance of three probability distributions, Weibull, Logistic, and Lognormal, was compared for wind speed modeling. The study highlighted that the Logistic distribution outperformed Weibull and Lognormal in certain cases, offering better accuracy for specific datasets. Nonetheless, these approaches heavily rely on static assumptions and often fail to adapt to rapidly changing meteorological conditions or seasonal variability.

The assessment of wind energy potential in Turkey, as discussed in [4], provides valuable insights into high-potential regions such as Marmara, Aegean, and Southeastern Anatolia, emphasizing favorable wind speeds and densities. Despite this, the study relies on historical averages and static probability distributions, which might not fully reflect short-term variations or long-term trends in wind speed data. Additionally, regional assessments often lack integration with predictive frameworks that could dynamically evaluate wind speed fluctuations for better resource planning.

The use of statistical tools like probability density functions (PDFs) for wind speed modeling is well-established. For instance, combining the Weibull function with wind rose diagrams allows a more comprehensive understanding of wind patterns throughout the year [3]. Wind rose diagrams provide critical information about wind direction and frequency, aiding in the assessment of wind regimes for energy projects [5]. However, these methods predominantly offer descriptive insights and do not inherently account for predictive or real-time applications.

Machine learning algorithms, such as support vector regression, random forests, and ensemble methods, have shown promise in predictive modeling of renewable energy systems [6,7]. Moreover, GIS-based multi-criteria decision-making has been explored for optimal site selection of renewable energy installations like solar power plants [8]. Despite these advancements, the application of machine learning models in wind energy often suffers from insufficient integration with statistical frameworks, leading to limited accuracy in capturing long-term wind speed trends.

In [9], the impact of wind direction on the power output and income of wind farms was explored. This research proposed a modified quadratic power curve to account for wind direction variability, offering a novel method for predicting wind turbine output. However, the study heavily relies on historical data to complete the wind datasets.

In [10], the feasibility of wind energy potential along the coastline of Pakistan is analyzed using predictive models and artificial neural networks (ANN) for forecasting wind data. While the study highlights Karachi as the most suitable location for wind farms, the ANN employed lacks sufficient precision in capturing long-term wind variability, limiting its reliability for accurate forecasting.

Long Short-Term Memory (LSTM) neural networks, in particular, have gained recognition for their effectiveness in time series analysis, making them ideal for wind speed prediction over extended periods [11]. However, past studies employing LSTM networks often overlook the incorporation of domain-specific statistical insights, such as Weibull or wind rose analysis, which could enhance model interpretability and robustness. This highlights the need for hybrid approaches that combine statistical methods with machine learning techniques to address gaps in adaptability, accuracy, and contextual understanding of wind speed variations.

Iran has made significant strides in the development of wind power plants, with notable projects scattered across the country. One of the earliest and most influential wind farms is the Manjil Wind Power Plant situated in Gilan. This pioneering onshore wind farm was commissioned in 1994 and boasts a capacity of around 90 MW. It played a pivotal role in jumpstarting wind energy production in Iran. Another remarkable wind farm in Iran is the Kahak Wind Farm located in Qazvin. It was commissioned in 2017 and has been inaugurated in two phases, ultimately reaching a final capacity of 100 MW. This sizable wind farm stands as one of the largest in the country. Similarly, in Qazvin, the Siahpoosh Wind Farm was commissioned in 2018 and has a capacity of 61.2 MW, contributing to the renewable energy landscape of the region. In addition to these larger wind farms, there are also smaller-scale installations that deserve recognition. One such example is the Khaf Wind Turbine in Khorasan Razavi, installed by Aria Razi Company. With a capacity of 2.5 MW, it was commissioned in 2015. Furthermore, the Aoun Ben Ali Wind Power Plant in Tabriz and the Safa Wind Power Plant in Isfahan each have capacities of 0.66 MW. Overall, wind power in Iran has made noteworthy progress, with a daily electricity generation capacity of approximately 600 MW from wind sources alone. However, considering the country's total electricity generation capacity of around 90,000 MW, there is ample scope for further growth and the establishment of new wind power plants in regions like Markazi Province to meet the growing energy demand [2].

While wind power plants have been successfully developed in various regions of Iran, including Gilan, Qazvin, Neyshabur, Khorasan Razavi, and Isfahan, there remains ample potential for further expansion. One such region that could greatly benefit from the establishment of a wind power plant is Markazi Province. This province boasts favorable conditions for wind energy production due to its strong and consistent winds. Furthermore, its central location within Iran, proximity to major population centers, and high electricity demand make it an ideal candidate for the development of a wind power plant. Such a project in Markazi Province could significantly contribute to Iran's overall electricity generation capacity. The efforts and dedication of Iran's Renewable Energy and Electricity Efficiency Organization have contributed to the acquisition of valuable insights through their website. By examining the map provided on the website, we observe the regions prone to wind, visualized through distinctive red dots. These areas signify immense potential for the harnessing of wind energy and serve as promising locations for future renewable energy projects in Markazi Province. Considering the rich data available from the meteorological stations and the continued efforts in renewable energy development, Markazi Province stands as a promising hub for advancing sustainable energy solutions within Iran's broader energy landscape [12].

This study offers an in-depth analysis of wind patterns in Markazi Province, Iran, with a focus on three towns in the province, Tafresh, Khomein, and Saveh, using a hybrid approach. This information is crucial for the assessment of wind power potential and the development of wind energy projects in the region. To facilitate the analysis of wind patterns in the region, comprehensive meteorological stations have been established in these cities. The Tafresh, Saveh, and Khomein meteorological stations, renowned for their cutting-edge technology and reliable data, serve as invaluable sources of information for wind energy enthusiasts and researchers alike. However, Weibull distribution and wind rose visualization are combined with LSTM networks for advanced wind resource assessment. The use of LSTM networks is expected to capture complex spatiotemporal dependencies in wind data for accurate forecasting of wind speeds at different altitudes. By leveraging the strengths of statistical tools and modern machine learning, the proposed approach provides superior insights into wind speed variability. The innovation of this study lies in its hybrid methodology, which combines traditional statistical techniques with state-of-the-art machine learning algorithms. This approach not only enhances the accuracy of wind energy potential assessments but also facilitates a deeper understanding of spatiotemporal wind behavior. Moreover, this research highlights the potential of Markazi Province as a hub for renewable energy development, addressing a critical gap in the literature. By demonstrating the utility of LSTM models in wind resource assessment, the study sets a precedent for future applications of AI-driven techniques in renewable energy planning.

This study has been folded as follows. In Section 2, we give some preliminaries. Section 3 analyses the wind data. LSTM is used to predict the wind speed in Section 4. Finally, the paper is concluded in Section 5.

2. Preliminaries

2.1. Dataset

In this study, we collected wind data from three meteorological stations Tafresh, Khomein, and Saveh for a period of two years, from 2018 to 2020. Tafresh, Khomein, and Saveh meteorological stations were chosen due to their strategic locations and availability of reliable wind data. These stations are equipped with advanced anemometers and meteorological instruments that accurately measure wind speed and direction. The data sampling was conducted at regular intervals of every 10 minutes, providing us with a comprehensive dataset to analyze wind patterns and assess wind power potential in the region. By collecting data at such high frequency, we were able to capture the fine-scale variations in wind behavior over two years. This level of temporal resolution allows for a detailed analysis of wind patterns and the identification of important trends and variations throughout different seasons and years.

The wind data collected from these stations serves as a valuable resource for understanding the wind characteristics in the region and determining the wind energy potential. It provides insights into the prevailing wind directions, average wind speeds and wind speed fluctuations at different times of the day.

Wind speed typically rises as altitude increases. Within the boundary layer, this rise occurs because friction diminishes at greater heights. In wind turbine engineering, the change in wind speed with elevation is often expressed relative to a standard measurement taken at 10 meters. This relationship can be modeled using a power law Equation, as shown below [13]:

$$V(h) = v(10)\left(\frac{h}{10}\right)^\alpha \quad (1)$$

Here, $V(h)$ represents the wind speed at a given height h , $V(10)$ is the wind speed recorded at the reference height of 10 meters by an anemometer, and α is an exponent that fluctuates between 0.11 and 0.40, depending on factors like surface roughness and atmospheric conditions. For a smooth, open landscape under neutral stability, α is commonly set at 0.14. Vallero demonstrated this power law approach using an exponent of $\frac{1}{7}$, which is roughly equivalent to 0.14. This value is suitable for low-roughness, exposed locations and has been widely adopted in research to map the vertical wind speed profile within the boundary layer. Accordingly, in our analysis, we applied an α value of 0.14 to compute wind speeds at heights of 50 meters, 80 meters, 100 meters, and 120 meters, based on wind speed data measured at the 10-meter anemometer level [14].

2.2. 2.1. Weibull parameters and probability assessment of wind power density

Generally, wind speed data well matches the Weibull shape. Many studies have used the Weibull distribution and the following equations to assess the properties of wind speed and the corresponding wind power densities at various places around the world [13]. The Weibull wind speed probability density function can be represented as Equation (2):

$$f(v) = \left(\frac{k}{c}\right) \left(\frac{v}{c}\right)^{k-1} \exp\left[-\left(\frac{v}{c}\right)^k\right] \quad (2)$$

Where $f(v)$ is the probability of observing wind speed v . Also, k is the dimensionless Weibull shape parameter, and c is the Weibull scale-parameter in m/s . The shape parameter determines the shape of the distribution curve, indicating whether the wind speed data is skewed or bell-shaped. On the other hand, the scale parameter represents the wind speed at which the distribution reaches its maximum value, also known as the most probable wind speed. The Weibull shape and scale parameters k and c are related to the mean wind speed v_m as Equation (3):

$$v_m = c\Gamma\left(1 + \frac{1}{k}\right) \quad (3)$$

where Γ is the gamma function. After estimating the mean and the variance of the wind speed data, Weibull parameters, k and c , can be calculated as Equations (4) and (5):

$$k = \left(\frac{\sigma}{v_m}\right)^{-1.086} \quad (4)$$

$$c = \frac{v_m}{\Gamma\left(1 + \frac{1}{k}\right)} \quad (5)$$

The most probable wind speed, $v_{mp}(m/s)$, defined as the most common wind speed for a given wind speed probability distribution function, can be expressed as Equation (6):

$$v_{mp} = c \left(\frac{k-1}{k}\right)^{1/k} \quad (6)$$

Wind speed corresponding to the maximum energy $v_{max}(m/s)$ can be calculated by using the Weibull parameters k and c as Equation (7):

$$v_{max} = c \left(\frac{k+2}{k}\right)^{\frac{1}{k}} \quad (7)$$

Wind power density $P_d(W/m^2)$ can be determined as Equation (8):

$$P_d = \frac{1}{2} \rho c^3 \Gamma \left(1 + \frac{3}{k}\right) \quad (8)$$

where ρ is the density of air in kg/m^3 [14,15].

2.3. LSTM neural network

LSTM is a type of artificial recurrent neural network (RNN) architecture that has gained significant popularity in the field of deep learning. It is designed to effectively capture and process long-term dependencies in sequential data, making it particularly suitable for tasks such as natural language processing, speech recognition, and time series analysis. Traditional RNNs suffer from the "vanishing gradient" problem, where the gradients diminish exponentially over time, making it difficult for the network to learn long-term dependencies. LSTM addresses this issue by introducing a memory cell and several gates that regulate the flow of information within the network [16]. So, the key component of an LSTM cell is the memory cell, which stores information over long sequences (see Figure 1). The cell has an internal state that can be selectively updated or forgotten based on the inputs and the current state. This makes LSTMs capable of retaining relevant information over extended periods, enabling them to handle sequences with long gaps between important events.

In addition to the memory cell, LSTMs contain three types of gates: the input gate, the forget gate, and the output gate. These gates are responsible for controlling the flow of information into and out of the memory cell [16,17]. The input gate determines which values from the input should be stored in the memory cell. It takes into account the current input and the previous hidden state. By applying a sigmoid activation function, it outputs values between 0 and 1, indicating how much of each input component should be stored [18]. The forget gate decides which information should be erased from the memory cell. It considers the current input and the previous hidden state and applies a sigmoid function to determine which parts of the memory cell should be forgotten. The output gate regulates the output of the LSTM cell. It combines the current input and the previous hidden state, passes them through a sigmoid function, and then applies the hyperbolic tangent function to the cell's current state to produce the final output.

During the training process, the parameters of the LSTM network, including the weights and biases, are learned using backpropagation through time. This involves computing the gradients of the loss function with respect to the network's parameters and updating them using optimization algorithms such as stochastic gradient descent [17,19]. By incorporating memory cells and gating mechanisms, LSTMs excel at learning from and predicting sequences, making them valuable tools in a wide range of applications [17-20].

Based on the connections shown in Figure 1, the mathematical expressions can be expressed as follows:

$$\text{Forget gate:} \quad f_t = \sigma(W_{fh}h_{t-1} + W_{fx}x_t + b_f) \quad (9)$$

$$\text{Input gate:} \quad i_t = \sigma(W_{ih}h_{t-1} + W_{ix}x_t + b_i) \quad (10)$$

$$\text{Candidate Cell State:} \quad \tilde{c}_t = \tanh(W_{ch}h_{t-1} + W_{cx}x_t + b_c) \quad (11)$$

$$\text{Cell State Update:} \quad c_t = f_t \cdot c_{t-1} + i_t \cdot \tilde{c}_t \quad (12)$$

$$\text{Output Gate:} \quad o_t = \sigma(W_{oh}h_{t-1} + W_{ox}x_t + b_o) \quad (13)$$

$$\text{Hidden State:} \quad h_t = o_t \cdot \tanh(c_t) \quad (14)$$

Where W_{fh} , W_{fx} , W_{ih} , W_{ix} , W_{ch} , W_{cx} , W_{oh} , and W_{ox} represent the weight matrices associated with different gates and transformations in the LSTM architecture. W_{fh} and W_{fx} are weighted for the forget gate, W_{ih} and W_{ix} for the input gate, W_{ch} and W_{cx} for the candidate cell state, W_{oh} and W_{ox} for the output gate. They determine how much influence the previous hidden state h and current input x have on the computation of each gate or transformation. h_{t-1} represents the previous hidden state at time $(t-1)$ while x_t denotes the input at time t . These are the main sources of information that LSTM cells use to update their internal states and produce outputs. b_f , b_i , b_c , and b_o are bias terms associated with the forget gate b_f , input gate b_i , candidate cell state b_c , and output gate b_o . Bias terms allow the LSTM to introduce shifts in the activation functions, aiding in learning and capturing relevant patterns in the data. c_t represents the cell state at time t , capturing and preserving long-term information. h_t denotes the hidden state or output of the LSTM cell at time t , which may be passed to subsequent layers or used for further processing. o_t represents the output gate activation, determining which parts of the cell state should be transmitted to subsequent stages. $\tilde{c}(t)$ denotes the candidate cell state, offering potential updates to the cell state. i_t represents the input gate activation, controlling the flow of new information into the cell state. f_t denotes the forget gate activation, determining what information from the previous cell state should be retained or discarded. Finally, c_{t-1} is the previous cell state, providing context for the update of the current cell state [17].

3. Analysis of wind data

The distribution of wind speeds plays a crucial role in the assessment of wind power potential for the installation of a wind power plant. In this study, the Weibull distribution function was utilized to analyze the wind distribution characteristics at three different wind stations in Tafresh, Khomein and Saveh. To better visualize the wind distribution patterns, Figure 2 presents the Weibull distribution graphs for the three wind stations. The x-axis represents wind speed, while the y-axis represents the probability density function (PDF).

Table 1 displays the scale and shape parameters obtained for each of the three wind stations. This distribution effectively models the statistical characteristics and variability of wind speed using two main parameters:

- Shape parameter (k): Represents the concentration or uniformity of the wind speed distribution. Higher values of (k) indicate a more uniform and narrower distribution of wind speeds.
- Scale parameter (c): Reflects the average wind speed, and has a significant impact on the amount of energy that can be extracted from the wind.
- Tafresh: Indicates low wind speeds and relatively wide variability.
- Khomein: Suggests higher wind speeds and more uniformity compared to Tafresh.
- Saveh: Represents the most uniform wind distribution and the highest average wind speed among the three regions.

The wind power density (WPD) is the measure of the amount of energy available in the wind at a specific location [19, 21-23]. It is calculated by multiplying the air density by the cube of the wind speed. WPD is usually expressed in watts per square meter (W/m²). The higher the WPD, the more suitable the location is for wind energy generation. In this study, we calculated the WPD for three meteorological stations in Iran: Tafresh, Khomein, and Saveh. We assumed a standard air density of 1.225 kg³ and a wind turbine height of 80 m.

The calculation of wind power density at an altitude of 80 meters indicates that Saveh, with 38.85 W/m² has the highest potential for wind energy exploitation. This value highlights the favorable wind conditions in the region for installing high-performance wind turbines. Khomein, with a wind power density of 16.17 W/m² also shows considerable potential for developing wind energy projects, particularly for medium-scale applications. In contrast, the wind power density in Tafresh, at 2.27 W/m² is very low, indicating that the wind conditions in this region are not economically viable for wind energy exploitation. This analysis underscores the importance of selecting suitable locations based on local wind data for designing and operating wind farms.

3.1. Applications of the Data

Estimating Wind Uniformity: Saveh, with the highest (k) value (5.45), has the most uniform wind distribution, meaning wind speeds in this region are concentrated within a specific range, and are more stable. This can contribute to more consistent turbine performance.

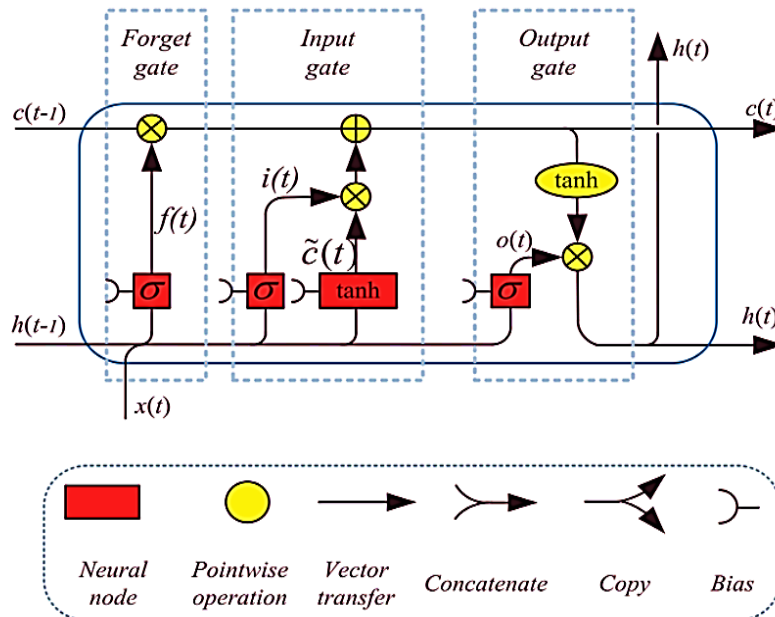

Figure 1. Architecture of LSTM with a forget gate [15].

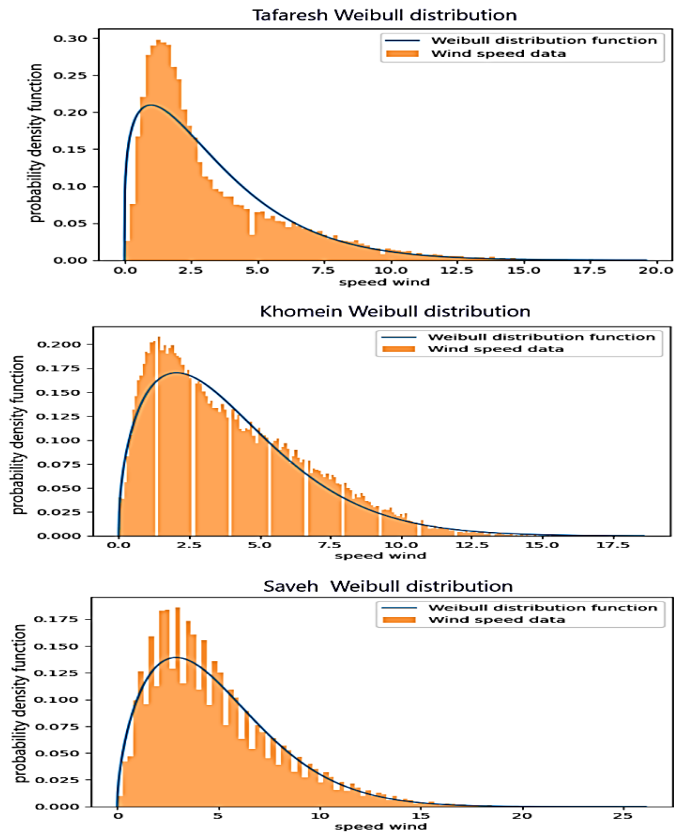

Figure 2. Weibull distribution graphs for the three wind stations.

Table 1. Shape parameters k (m/s) and scale parameters c (m/s) in the 2018-2020 period.

Parameters	Tafresh	Khomein	Saveh
K	4.06	4.37	5.45
C	1.19	2.3	3.1

Evaluating Energy Production Potential: The (c) parameter in Saveh (3.1) and Khomein (2.3) indicates higher average wind speeds compared to Tafresh (1.19), suggesting greater potential for wind energy production in these regions.

Designing Suitable Turbines: Using the Weibull distribution data, turbines can be selected to match the wind speed distribution of each region. For example, turbines for Khomein and Saveh should be designed for higher wind speeds.

Prediction with LSTM Models: Weibull parameters are key inputs for LSTM models to predict the temporal trends and variations in wind speed over different periods.

Economic and Engineering Analysis: Weibull data indicates that Saveh, with higher uniformity and greater average wind speed, is a suitable option for wind energy investment. In contrast, Tafresh, due to its lower wind speeds, may not be economically viable for wind energy projects.

4. Wind Data Analysis Using LSTM

Modeling the wind data in the previous section and calculating the scale and shape parameters can help us in analyzing the wind speed in the area. Using these parameters obtained by artificial intelligence, which uses a two-layer LSTM network, the speed can be predicted, and the generated power will help in the future, in this way, we achieved very good accuracy. Figure 3 showcases a comparison between the actual and predicted wind speeds at the Khomein, Tafresh, and Saveh wind stations in the central province of Iran. The x-axis represents the sample index, while the y-axis represents the wind speed in meters per second. In Figure 3, the blue line represents the actual wind speeds recorded at the respective stations. These values serve as the ground truth for evaluating the accuracy of the wind forecasting model. The orange line, on the other hand, represents the predicted wind speeds generated by the two-layer algorithm of artificial intelligence. Upon visual inspection, it is evident that the predicted wind speeds closely align with the actual wind speeds. The model successfully captures the underlying patterns and trends in the wind data, resulting in accurate predictions. The closeness of the red line to the blue line indicates the model's ability to capture the dynamics of wind

behavior in the central province of Iran. The figure provides valuable insights into the performance of the two-layer algorithm in wind forecasting. It demonstrates the algorithm's effectiveness in capturing the complex relationships and dependencies in the wind data, enabling accurate predictions.

Figure 4 shows the wind roses derived from the actual measured data. The LSTM-based predictions were compared, and they demonstrated a remarkably close resemblance. The wind direction distribution and wind speed frequencies exhibited a strong alignment, indicating the effectiveness of the LSTM algorithm in capturing the underlying patterns and characteristics of the wind behavior in the study areas. The level of approximation between the real and predicted wind roses suggests the reliability and potential utility of the LSTM model for wind forecasting in the Markazi Province of Iran.

In this study, wind forecasting was performed in three stations, namely Tafarsh, Khomein, and Saveh, located in the Markazi Province of Iran. The wind patterns observed at these stations were compared with the predictions generated by the double-layer LSTM (Long Short-Term Memory) algorithm. To evaluate the performance and accuracy of the algorithm, three important evaluation metrics were utilized: Mean Squared Error (MSE), Mean Absolute Error (MAE), and R-squared coefficient.

MSE represents the average squared difference between the predicted wind values and the observed wind values at each station. It provides a measure of the model's ability to minimize prediction errors. Similarly, MAE indicates the average absolute difference between the predicted and observed wind values, giving insights into the magnitude of errors. Additionally, the R-squared coefficient, also known as the coefficient of determination, assesses the goodness-of-fit of the predicted wind values against the actual wind values. It represents the proportion of variance in the observed wind patterns that can be explained by the LSTM model. A higher R-squared value indicates a better fit and higher predictive accuracy.

To present a comprehensive analysis, these evaluation metrics were calculated for all three stations, and the results are tabulated in Table 2. The table provides a concise summary of the model's performance, allowing for a direct comparison of MSE, MAE, and R-squared values across the stations. The inclusion of this table enhances the clarity and transparency of our findings, enabling readers to easily interpret and assess the predictive capabilities of the double-layer LSTM algorithm in wind forecasting.

Table 2. Three parameters to measure the accuracy of the obtained model for three stations.

	Tafresh	Khomein	Saveh
MSE	0.0017	0.0029	0.0012
MAE	0.0292	0.0377	0.0256
R-squared	0.8838	0.8719	0.9183

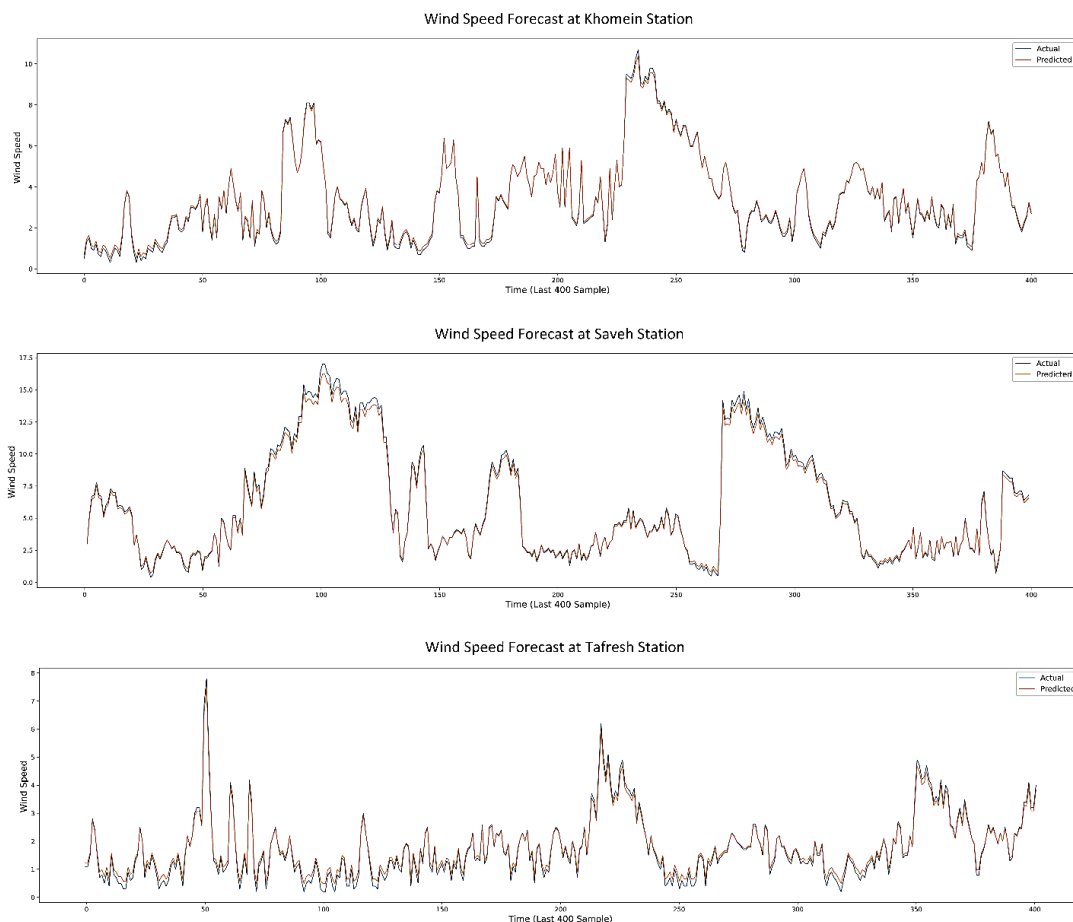

Figure 3. Comparison between the actual and predicted wind speeds at Khomein, Tafarsh and Saveh.

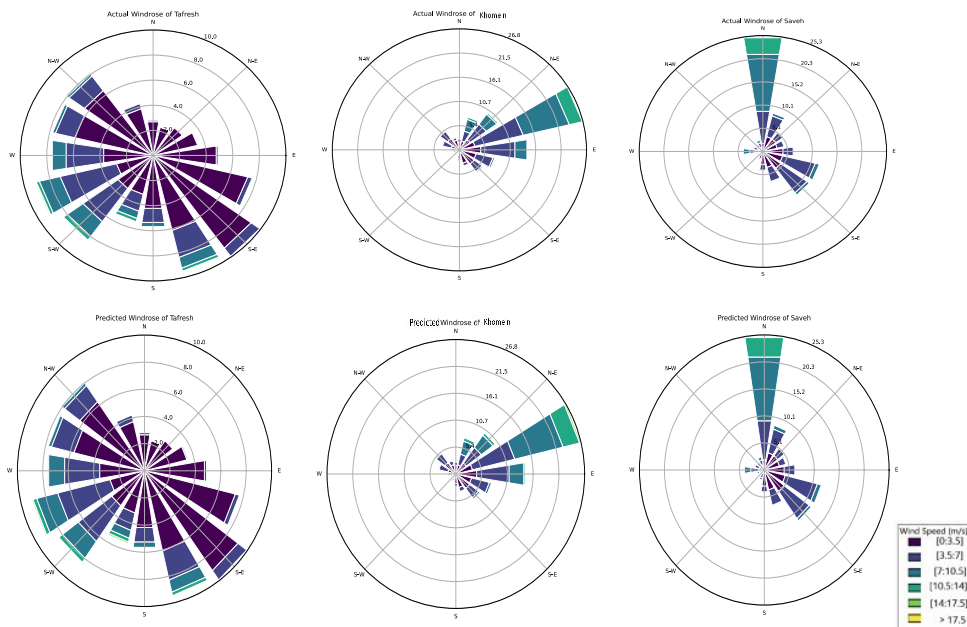

Figure 4. Comparison between actual and predicted wind roses of three stations in the two years of 2018-2020.

5. Conclusion

This study provides a detailed assessment of wind energy potential in Markazi Province, Iran, focusing on the cities of Tafresh, Khomein, and Saveh. Using a combination of statistical methods and artificial intelligence techniques, it evaluates wind patterns, temporal variations, and energy potential in these regions. Data collected over a two-year period from advanced meteorological stations formed the basis for analyzing wind speed and direction, enabling a comprehensive understanding of wind behavior.

The Weibull distribution and wind rose diagrams revealed significant variations in wind characteristics across the three locations. Saveh emerged as the most suitable area for wind energy development, given its consistent and higher wind speeds, while Khomein showed moderate potential for medium-scale projects. Conversely, Tafresh exhibited limited wind energy potential, making it economically unsuitable for large-scale wind farm investments.

The use of Long Short-Term Memory (LSTM) neural networks added value by predicting wind speeds and temporal patterns with high accuracy. The alignment between the actual and predicted data validated the model's reliability in capturing wind dynamics, including direction and frequency. This predictive capability is crucial for planning future wind energy projects and optimizing energy production strategies.

The calculation of wind power density (WPD) further supported these findings, with Saveh showing the highest potential for efficient wind energy exploitation. These insights underline the importance of site-specific data in designing wind farms and selecting appropriate technologies for maximum efficiency.

This research demonstrates the effectiveness of combining statistical and machine learning techniques in wind resource assessment. By leveraging these approaches, decision-makers can make informed choices about renewable energy investments, enhancing sustainability in energy production. Additionally, the study emphasizes the role of wind energy in reducing dependence on fossil fuels, mitigating environmental impacts, and supporting Iran's goals for sustainable development.

References

- [1] T. V. Ramachandra, and B. V. Shruthi, "Spatial Mapping of Renewable Energy Potential," *Renewable and Sustainable Energy Reviews*, vol. 11, no. 7, pp. 1460–1480, 2007.
- [2] M. Bahrami, and P. Abbaszadeh, "An Overview of Renewable Energies in Iran," *Renewable and Sustainable Energy Reviews*, vol. 24, pp. 198–208, 2013.
- [3] J. Wu, J. Wang, and D. Chi, "Wind Energy Potential Assessment for the Site of Inner Mongolia in China," *Renewable and Sustainable Energy Reviews*, vol. 21, pp. 215–228, 2013.
- [4] C. İlkiliç, "Wind Energy and Assessment of Wind Energy Potential in Turkey," *Renewable and Sustainable Energy Reviews*, vol. 16, no. 2, pp. 1165–1173, 2012.
- [5] M. D. Farahani, S. Sharafi, and A. Farahani "Application of Remote Sensing in Wind Power Plant Location," *Journal of Green Energy Research and Innovation*, vol. 2, no. 1, pp. 57-65, 2025.
- [6] L. Roubeyrie, and S. Celles, "Windrose: A Python Matplotlib, Numpy Library to Manage Wind and Pollution Data, Draw Windrose," *Journal of Open Source Software*, vol. 3, no. 29, 268, 2018.
- [7] M. W. Ahmad, J. Reynolds, and Y. Rezgui, "Predictive Modelling for Solar Thermal Energy Systems: A Comparison of Support Vector Regression, Random Forest, Extra Trees and Regression Trees," *Journal of Cleaner Production*, vol. 203, pp. 810–821, 2018.
- [8] R. Pandit, D. Infield, and M. Santos, "Accounting for Environmental Conditions in Data-Driven Wind Turbine Power Models," *IEEE Transactions on Sustainable Energy*, vol. 14, no. 1, pp. 168–177, 2023.
- [9] A. A. Karimi Taleb, H. Makvandi, and A. Oraee, "The Impact of Wind Direction on Wind Farms' Output Power and Income," *Journal of Green Energy Research and Innovation*, vol. 1, no. 1, pp. 34–47, 2024.

- [10] S. S. Ahmad, A. Al Rashid, et al., "Feasibility Analysis of Wind Energy Potential Along the Coastline of Pakistan," *Ain Shams Engineering Journal*, vol. 13, no. 1, 101542, 2022.
- [11] A. Karamali, A. Daeichian, and S. Rezaei, "Using Long Short-Term Memory Networks as Virtual Wind Direction Sensors for Improved Wind Farm Turbines Orientation," *2024 9th International Conference on Technology and Energy Management (ICTEM)*, pp. 1–5, 2024.
- [12] H. Yousefi, H. Hafeznia, and A. Yousefi-Sahzabi, "Spatial Site Selection for Solar Power Plants Using a GIS-Based Boolean-Fuzzy Logic Model: A Case Study of Markazi Province, Iran," *Energies*, vol. 11, no. 7, 1648, 2018.
- [13] E. Kavak Akpınar, and S. Akpınar, "A Statistical Analysis of Wind Speed Data Used in Installation of Wind Energy Conversion Systems," *Energy Conversion and Management*, vol. 46, no. 4, pp. 515–532, 2005.
- [14] A. Mayhoub, and A. Azzam, "A Survey on the Assessment of Wind Energy Potential in Egypt," *Renewable Energy*, vol. 11, no. 2, pp. 235–247, 1997.
- [15] H. Bagiorgas, M. Assimakopoulos, D. Theoharopoulos, D. Matthopoulos, and G. Mihalakakou, "Electricity Generation Using Wind Energy Conversion Systems in the Area of Western Greece," *Energy Conversion and Management*, vol. 48, no. 5, pp. 1640–1655, 2007.
- [16] H. Arslan, H. Baltacı, B. O. Akkoyunlu, S. Karanfil, and M. Tayanc, "Wind Speed Variability and Wind Power Potential Over Turkey: Case Studies for Çanakkale and İstanbul," *Renewable Energy*, vol. 145, pp. 1020–1032, 2020.
- [17] A. Sherstinsky, "Fundamentals of Recurrent Neural Network (RNN) and Long Short-Term Memory (LSTM) Network," *Physica D: Nonlinear Phenomena*, vol. 404, 132306, 2020.
- [18] X. Le, H. V. Ho, G. Lee, and S. Jung, "Application of Long Short-Term Memory (LSTM) Neural Network for Flood Forecasting," *Water*, vol. 11, no. 7, p. 1387, 2019.
- [19] X. Song, Y. Liu, et al., "Time-Series Well Performance Prediction Based on Long Short-Term Memory (LSTM) Neural Network Model," *Journal of Petroleum Science and Engineering*, vol. 186, 106682, 2020.
- [20] G. Van Houdt, C. Mosquera, and G. Nápoles, "A Review on the Long Short-Term Memory Model," *Artificial Intelligence Review*, vol. 53, no. 8, pp. 5929–5955, 2020.
- [21] M. Ghouchani, M. Taji, A. S. Cheheliani, and M. S. Chehr, "Developing a Perspective on the Use of Renewable Energy in Iran," *Technological Forecasting and Social Change*, vol. 172, 121049, 2021.
- [22] M. G. N. M. Abad, A. A. Ghadimi, M. Ebadi, and A. Daeichian, "Lyapunov-Based Model Predictive Control for a Single-Phase Grid-Connected Cascaded Multilevel Asymmetrical Inverter," *International Journal of Electrical Power & Energy Systems*, vol. 147, 108789, 2023.
- [23] M. Pirzadi, A. A. Ghadimi, and A. Daeichian, "Distributed Multi-Agent Transmission System Restoration Using Dynamic Programming in an Uncertain Environment," *Electric Power Systems Research*, vol. 196, 107270, 2021.

Declaration of competing interest

The authors declare that they have no known competing financial interests or personal relationships that could have appeared to influence the work reported in this paper. The ethical issues, including plagiarism, informed consent, misconduct, data fabrication and/or falsification, double publication and/or submission, redundancy, have been completely observed by the authors.

Bibliography



Amir Hossein Karamali was born in 2000 in Mahallat, Iran. He completed his bachelor's degree in Electrical Engineering at Arak University in 2022, and is currently pursuing a master's degree in Power Electronics and Electric Machines at Iran University of Science and Technology (IUST). His research focuses on power electronics and the application of artificial intelligence in power systems, aiming to contribute to the development of advanced technologies for a sustainable future.

Email: amirhosseinkaramali@gmail.com

ORCID: [0009-0008-2320-9719](https://orcid.org/0009-0008-2320-9719)

Contribution Statement: Data curation, Formal analysis, Software, Validation, Visualization, Roles/Writing-original draft.



Abolghasem Daeichian was born in Iran, in 1982. He received the Bachelor's degree in electrical engineering from the Isfahan University of Technology in 2003, and the M.Sc. and Ph.D. degree in control engineering from Shiraz University and Isfahan University of Technology in 2006 and 2014, respectively. He visited Australian National University in 2012. Since 2017, he has been with the Department of Electrical Engineering, Faculty of Engineering, Arak University, where he is currently an Associate Professor. He was the head of Research Institute of Renewable Energy, Arak University, Arak, Iran from 2021 to 2023 and the IT manager at Arak University from 2023 to 2024. His research interests include estimation & filtering, stochastic control, quantum control, and cyber-physical systems. Dr. Daeichian is a fellow of the Iranian Society of Instrumentation and Control Engineers.

Email: a-daeichian@araku.ac.ir

ORCID: [0000-0002-6318-579X](https://orcid.org/0000-0002-6318-579X)

Contribution Statement: Conceptualization, Methodology, Project administration, Supervision, Writing-review & editing.



Saber Rezaei was born in 1996 in Tehran, Iran. He completed his bachelor's degree in Electrical Engineering with a focus on Control Engineering at Semnan University in 2020. Currently, he is pursuing a Master's degree in Neurocognitive Engineering at Iran University of Science and Technology (IUST). His expertise lies in signal processing, artificial intelligence and machine learning, with a particular interest in deep learning and its applications in biomedical engineering.

Email: s-rezaei@elec.iust.ac.ir

ORCID: [0009-0002-3733-2108](https://orcid.org/0009-0002-3733-2108)

Contribution Statement: Data curation, Formal analysis, Software, Validation, Visualization, Roles/Writing-original draft.



Ali Reihanian received his B.Sc. degree in Information Technology (IT) from Mazandaran University of Science and Technology, Iran, in 2011. He received his M.Sc. degree in Information Technology (IT), with special focus on Artificial Intelligence, from Mazandaran University of Science and Technology, Iran, in 2014. He also received his Ph.D. degree in Artificial Intelligence and Robotics from University of Tabriz, Iran, in 2018. Since 2021, he has been with the Department of Computer Engineering, Faculty of Engineering, Arak University, where he is currently an Assistant Professor. Also, he has been the head of Research Institute of Artificial Intelligence, Arak University, Arak, Iran, since 2023. His research interests include machine learning and pattern recognition, social network analysis, natural language processing and data mining.

Email: a-reihanian@araku.ac.ir

ORCID: [0000-0001-6668-3535](https://orcid.org/0000-0001-6668-3535)

Contribution Statement: Methodology, Supervision, Writing-review & editing.